

Made in the USA

6153

PANEL REMOTE DISPLAY

06250ML-01



This device is marked with the international caution symbol. It is important to read the Setup Guide before installing or commissioning this device as it contains important information relating to safety and EMC.

It is the policy of NEWPORT to comply with all worldwide safety and EMC/EMI regulations that apply. NEWPORT is constantly pursuing certification of its products to the European New Approach Directives. NEWPORT will add the CE mark to every appropriate device upon certification.

© Copyright 1999, NEWPORT Electronics, Inc. All rights reserved.

This documentation may not be copied, photocopied, reproduced, translated, or reduced to any electronic medium or machine-readable form, in whole or in part, without prior written consent of NEWPORT Electronics, Inc.

CHG	ECO NO	DATE	BY	CHK
D	9574	02 FEB 99	TB	KAH

TABLE OF CONTENTS

SAFETY CONSIDERATIONS		ii
1.0	GENERAL INFORMATION	
1.1	Description	1
1.2	Option Codes	1
2.0	SPECIFICATIONS	
2.1	Display Characteristics	2
2.2	Data and Control Input Characteristics	2
2.3	Input Signal Requirements	2
2.4	Operating Environment	2
2.5	Power	3
2.6	Mechanical	3
3.0	MECHANICAL ASSEMBLY AND INSTALLATION	
3.1	Panel Mounting	4
4.0	OPERATING INSTRUCTIONS	
4.1	Introduction	5
4.2	Power	6
4.3	Data Input	7
4.4	External Control Signals	8
4.5	Annunciator Options	10
5.0	DRAWINGS	12
ILLUSTRATIONS		
Figure 3-1	DIN Case Dimensions	4
Figure 4-1	5 V dc Wiring Detail	6
Figure 4-2	Visual Display of Logic Input	7
Figure 4-3	Strobe Polarity Inputs	9
Figure 4-4	Pin Assignments	11
Figure 5-2	Assembly Diagram (1 of 2)	12
Figure 5-3	Assembly Diagram (2 of 2)	13
Figure 5-4	Schematic Diagram	14

SAFETY CONSIDERATIONS



This device is marked with the international Caution symbol. It is important to read this manual before installing or commissioning this device as it contains important information relating to Safety and EMC (Electromagnetic Compatibility).

Unpacking & Inspection



Unpack the instrument and inspect for obvious shipping damage. Do not attempt to operate the unit if damage is found.

This instrument is a panel mount device protected in accordance with Class I of EN 610 (115/230 AC power connections). Installation of this instrument should be done by Qualified personnel. In order to ensure safe operation, the following instructions should be followed.

This instrument has no power-on switch. An external switch or circuit-breaker shall be included in the building installation as a disconnecting device. It shall be marked to indicate its function, and it shall be in close proximity to the equipment within easy reach of the operator. The switch or circuit-breaker shall not interrupt the Protective Conductor (Earth wire), and shall meet the relevant requirements of IEC 947-1 and IEC 947-3 (International Electrotechnical Commission). The switch shall not be incorporated in the mains supply circuit.

Furthermore, to provide protection against excessive energy being drawn from the mains supply in case of a fault in the equipment, an overcurrent protection device shall be installed.



- The **Protective Conductor** must be connected for safety reasons. Check that the power cable has the proper Earth wire, and it is properly connected. It is not safe to operate this unit without the Protective Conductor Terminal connected.



- Do not exceed voltage rating on the label located on the top of the instrument housing.
- Always disconnect power before changing signal and power connections.
- Do not use this instrument on a work bench without its case for safety reasons.
- Do not operate this instrument in flammable or explosive atmospheres.
- Do not expose this instrument to rain or moisture.
- Unit mounting should allow for adequate ventilation to ensure instrument does not exceed operating temperature rating.
- Use electrical wires with adequate size to handle mechanical strain and power requirements. Install without exposing bare wire outside the connector to minimize electrical shock hazards.

EMC Considerations

- Whenever EMC is an issue, always use shielded cables.
- Never run signal and power wires in the same conduit.
- Use signal wire connections with twisted-pair cables.
- Install Ferrite Bead(s) on signal wires close to the instrument if EMC problems persist.

This page intentionally left blank.

1.0 GENERAL INFORMATION

1.1 DESCRIPTION

The Model 6153 is a +5 V dc powered remote Display that accepts logic level data inputs and displays the corresponding numeric information on 14mm high 7-segment LED readouts. The input logic data code may be parallel BCD (0-9) or octal (0-7). All components are housed in a tough molded case.

Input data storage is provided and may be used by applying a signal to the strobe input while the desired input data is present. A steady true level on the strobe input allows the displayed data to follow the input data. Two strobe inputs are provided to allow several different strobing modes.

A blanking input allows the display to be blanked upon command. Stored data may be retained or new data stored during blanking.

Decimal points are available to the right of the four most significant digits and more than one may be lighted simultaneously. The decimal points are neither stored or blanked.

The standard instrument has a display capability of 99999 counts and can be converted to -19999 count capability by ordering the Left Annunciator Option. The Right Annunciator Option replaces the rightmost digit with three horizontal bars. All three bars can be independently lighted and can be used to denote selectable engineering units.

1.2 OPTION CODES

<u>Model/Option</u>	<u>Description</u>
6153	Basic Model 6153 Remote Display Module, 99999 counts, +5 V dc operation
AR	Right Annunciator (≡)
ALP	Left Annunciator (-1) see Par. 4.5.1
ALN	Left Annunciator (-1) see Par. 4.5.2
D1	One PC edge connector with solder terminals

2.0 SPECIFICATIONS

2.1 DISPLAY CHARACTERISTICS

Type	7-segment LED
Size	14 mm high
Capacity	99999 standard -19999 with Left Annunciator Option 9999 \equiv with Right Annunciator Option Standard (may be disabled)
Storage Blanking	To the right of the four most significant digits Display blanks on command

2.2 DATA CONTROL INPUT CHARACTERISTICS

Data Codes	BCD and Octal
DC strobe	Selectable high or low level true 2 μ s minimum width
AC strobe	Selectable rising or falling edge strobe. Maximum 1 μ s transition time. Should be settled for 10 μ s before transition.
Blanking	Low level blanks display
Decimal points	Grounding decimal point input lights corresponding decimal point.

2.3 INPUT SIGNAL REQUIREMENTS

BCD Inputs	Low level: -0.5 V to +0.5 V, sink 0.4 mA High level: +2.4 V to +5.0 V, source 40 μ A
POLARITY and STROBE inputs	Low level: -0.5 V to +0.5 V, sink 3.2 mA High level: +2.4 V to +5.0 V, source 80 μ A
<u>BLANKING</u>	Low level: -0.5 V to +0.5 V, sink 8 mA High level: +2.4 V to +5.0 V, source 200 μ A
RIGHT ANNUNCIATOR inputs	TOP BAR: Same as POLARITY and STROBE inputs MIDDLE BAR: Same as BCD inputs BOTTOM BAR: Same as BCD inputs

2.0 SPECIFICATIONS (continued)

2.4 OPERATING ENVIRONMENT

Temperature	0°C to +50°C
Humidity	0 to 95% at < 40°C

2.5 POWER

Input Voltage	+4.75 to 5.25 V dc
Input power	3.8W max

2.6 MECHANICAL

Weight	145 g (5 oz)
Bezel (WxHxT)	96 x 25.72 x 5 mm (3.77 x 0.94 x .19 in)
Depth behind bezel (with connector)	77 mm (3.0 in)
Panel cutout	92 x 22.2 mm (3.622 x .874 in)
Connector (furnished with D1 Option)	

Types:	SCU	SCA 15D/1-2
	Elco	00-6007-030-450-812
Key:	SCU	007900
	Elco	60-6007-4828
Key position:		Between pin 4 and pin 5

3.0 MECHANICAL ASSEMBLY AND INSTALLATION

3.1 PANEL MOUNTING

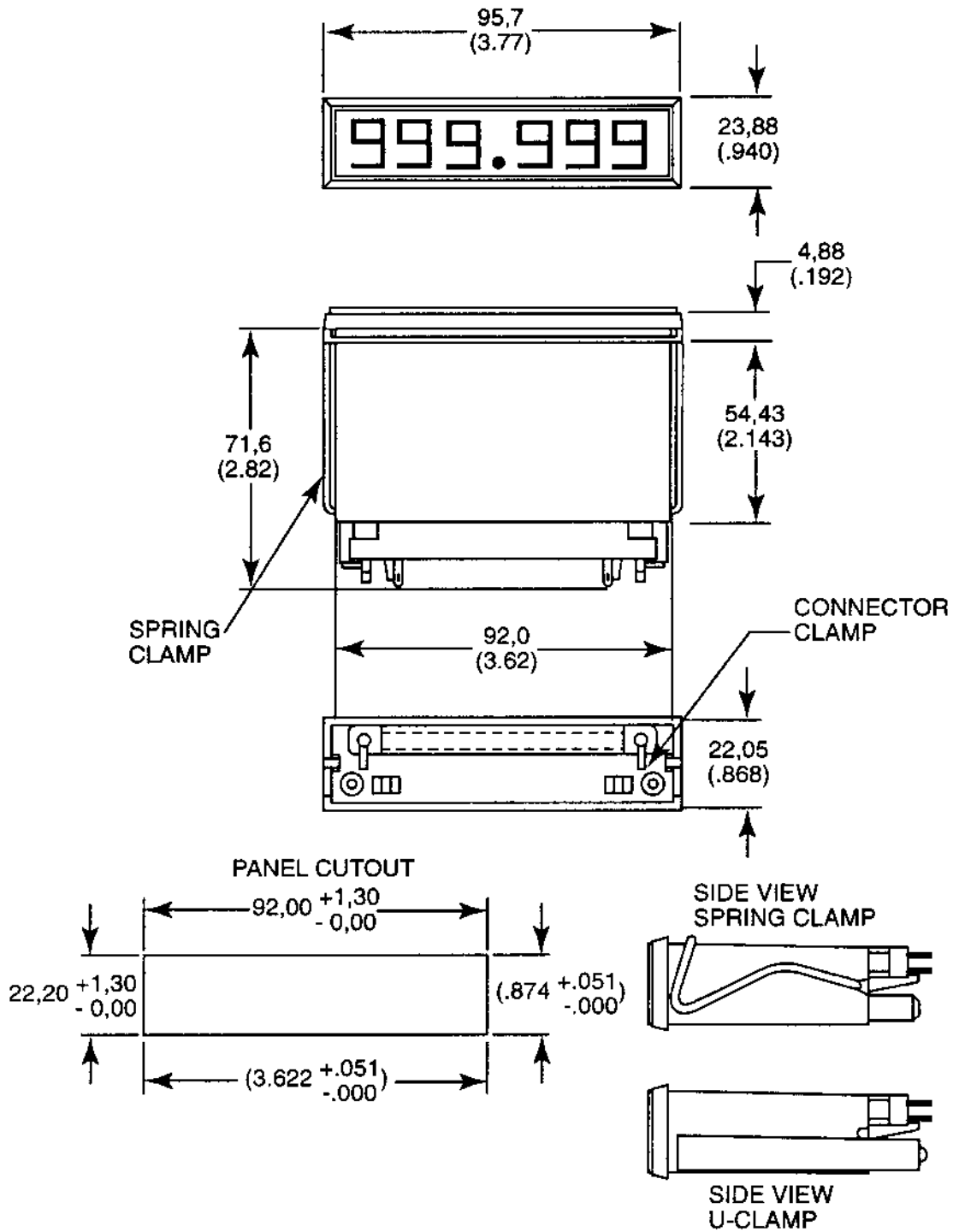

2. PANEL THK. 6,4 (.25) MAX., 0,8 (.03) MIN.
 1. DIMENSIONS IN MILLIMETERS AND (INCHES).
- NOTES: UNLESS OTHERWISE SPECIFIED.

Figure 3-1 DIN Case Dimensions

3.1.1 Spring Clamp Mounting

1. Remove the spring clamp by lifting it toward the rear of the case and pulling one side of the clamp out of the case. Slide out the other side of the clamp.
2. Insert the case into the panel cutout (see Section 3.1).
3. Reinstall the spring clamp onto the case and rotate the clamp toward panel until it secures the case to the panel.

NOTE: The spring clamp may be used for desk-top viewing by simply rotating the clamp toward the bottom of the case. The case will be supported by the two v-shaped feet.

3.1.2 U-Clamp Mounting

1. Use a #8 Phillips-head screwdriver to remove the two screws on the rear of the case and then remove the U-clamp from the case.
2. Insert the case into the panel cutout (see Section 3.1).
3. Slide the U-clamp back onto the case, and insert and tighten the two screws. This should hold the case firmly against the panel. Do not overtighten.

4.0 OPERATING INSTRUCTIONS

4.1 INTRODUCTION

The Model 6153 is a compact self-contained panel mounted Remote Display that accepts parallel BCD or Octal data, retains it in storage, and displays it on 7-segment LED readouts. All components are housed in a tough molded case and all connections to the instrument are made to the printed circuit connector at the rear of the case.

The standard instrument has 99999 count capability with two options extending this capability to include a left-hand overrange 1 and minus sign, and a right-hand engineering units annunciator. 5 V power input is standard.

Input data should be of a positive true, parallel BCD or Octal format and should have TTL compatible logic levels.

Input data is connected to internal data latches which can be strobed to store and display data indefinitely or can be commanded to follow and display the data as it appears. The latches can be wired to strobe the data into storage on either a positive or negative pulse (or level) or on a positive or negative transition.

4.2 POWER

The standard Model 6153 Remote Display operates from a +5 V $\pm 5\%$ power source.

4.2.1 DC Operation

In dc operation the Remote Display should be connected to a +5 V $\pm 5\%$ power source capable of supplying a steady state current of 800 mA or more. Care must be taken when connecting the input, control, and power supply ground lines to insure that a ground loop is not formed. It is suggested that all ground connections be made at the same node, preferably at the ground terminal of the Remote Display

Wiring Detail, 5 V dc Power Operation

- Connect the positive lead of the 5 V power source to Pin 12.
- Connect the negative lead (ground reference) of the 5 V power source to Pin P.

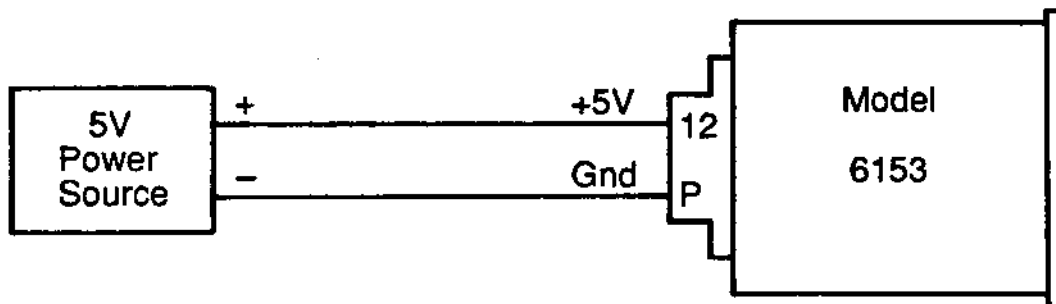

Figure 4-1 5 V dc Wiring Detail

Recommended Power Source Specifications

Input voltage at J1 (static or instantaneous)	4.75 V min 5.25 V max
Ripple (50 Hz to 120 Hz)	10 mV rms
Noise (above 120 Hz)	10 mV rms
Output Impedance (including interconnect wiring)	0.5 ohm max

4.3 DATA INPUTS

The BCD data inputs are connected to J1 as shown in Figure 4-4 Pin Assignments. Octal data (3-wire, 0-7) may be accommodated by grounding the "9" bit of each decade. The data inputs should be positive true, TTL compatible and must be stable before being strobed into storage. The truth table for these inputs appears in Figure 4-2.

Logic Input				Visual Display
8	4	2	1	
0	0	0	0	0
0	0	0	1	1
0	0	1	0	2
0	0	1	1	3
0	1	0	0	4
0	1	0	1	5
0	1	1	0	6
0	1	1	1	7
1	0	0	0	8
1	0	0	1	9
1	0	1	0	-
1	0	1	1	E
1	1	0	0	H
1	1	0	1	L
1	1	1	0	P
1	1	1	1	Blank**

**An open input assumes a logic "1". Leaving BCD data unconnected blanks that digit.

Figure 4-2 Visual Display of Logic Input

4.4 EXTERNAL CONTROL SIGNALS

4.4.1 Strobe

The Model 6153 contains data latches which store input BCD data which is entered into storage by a strobe signal applied to either the ac or dc strobe inputs. Data can be strobed into storage on either a positive or negative pulse or at a positive or negative transition. The storage feature may be disabled to allow the display to follow the data inputs on a continuous basis. All elements of the display are strobed into storage except the decimal points and the top element of the optional right annunciator display.

AC Strobe (J1-14)

An ac strobe input is provided to strobe data into storage at either the positive or negative edge of a strobe signal. The strobe signal should be 2 μ s minimum in width, settled for 10 μ s or more before the strobing transition and have rise and fall times of 1 μ s or less. If data is to be strobed into storage at the negative transition of the strobe signal connect the ac strobe input to the strobe signal and connect the dc strobe and strobe polarity inputs to logic levels per line 1 of Figure 4-3. Line 2 of Figure 4-3 indicates the connections to be made when data is to be strobed into storage on the positive transition of the strobe signal.

DC Strobe (J1-11)

If data is to be strobed into storage continuously for the duration of the strobe signal, the dc strobe input should be connected to the strobe signal. If the storage is to be continuously updated whenever the strobe signal is low, connect the dc strobe input to the strobe signal and connect the ac strobe and strobe polarity inputs to logic levels per line 3 of Figure 4-3. Line 4 of Figure 4-3 indicates the connections to be made when data is to be continuously strobed into storage whenever the strobe signal is high. The minimum strobe width is 2 μ s in either condition. The storage feature can be disabled by hardwiring a continuous strobe signal into the dc strobe input.

4.4.2 Strobe Polarity (J1-13)

The strobe polarity input is used in conjunction with the unused strobe input to select the polarity of the used strobe input. Refer to Figure 4-3 for connection information.





LINE	INPUT TO PRODUCE STROBE	AC STROBE (J1-14)	DC STROBE (J1-11)	STROBE POLARITY (J1-13)
1.	 Negative Transition	Strobe Signal Input	High	Low
2.	 Positive Transition	Strobe Signal Input	Low	High
3.	 Low Pulse (or Level)	High	Strobe Signal Input	Low
4.	 High Pulse (or Level)	Low	Strobe Signal Input	High

Figure 4-3 Strobe Polarity Inputs

4.4.3 Blanking (J1-S)

A low logic level on the Blanking input blanks all the display elements except the decimal points and the top bar of the optional annunciator display. The storage function remains functional during blanking.

4.4.4 DP1-DP4 (J1-N, L, 4, 10)

The DP1-DP4 inputs control the right-hand decimal points with DP1 to the right of the most significant digit. Grounding a DP input causes the corresponding decimal point to light. The decimal points are not stored. If the decimal point is grounded by a transistor or passive pull-up IC, it must be capable of sinking 15 mA.

4.4.5 +5 V (J1-12)

The +5 V power should be connected to J1-12 with ground return connected to J1-P per Section 4.2.1 .

4.4.6 Ground (J1-P)

All inputs and outputs are referenced to circuit ground. This pin may be used to connect a constant low logic level to any input.

4.5 ANNUNCIATOR OPTIONS

The Model 6153 Remote Display is normally supplied with five, all numeric digits; however, the leftmost digit is replaced with an annunciator having the capability to display the symbols (-) and (1) independently or together in the Left Annunciator Option. The one symbol input is positive true whereas the minus polarity symbol input may be ordered either positive or negative true.

The Right Annunciator Option replaces the rightmost digit with an annunciator capable of displaying three horizontal bars which may be used as an indicator of engineering unity by applying the appropriate designations to the front panel.

4.5.1 Left Annunciator Option, (ALP) (J1-K & 9)











This option replaces the leftmost digit with an annunciator having the capability to display the minus and one symbols. The minus symbol is lit by applying a low logic level to the + Polarity Input (J1-K). A high logic level applied to this input extinguishes the minus sign indicating a positive data input. The one symbol is lit by applying a high logic level to the 10 k input (J1-9). Both the minus sign and the one symbol are stored and are strobed into storage along with the BCD data.

4.5.2 Left Annunciator Option, (ALN) (J1-15 & 9)

The Left Annunciator Option, - Polarity, is identical to the Left Annunciator Option, + Polarity, with the exception of the polarity signal input which becomes negative true and is located at J1-15. This option makes the instrument compatible with data sources that have a Polarity Output that is high for negative polarity data.

4.5.3 Right Annunciator Option (J1-1, 2, 4)



The Right Annunciator Option replaces the rightmost digit with an annunciator capable of displaying three horizontal bars which may be controlled independently. The top bar is controlled by J1-2, the middle bar by J1-1, and the bottom bar by J1-4. A high level on any of these pins will cause the corresponding horizontal bar to light. The middle bar and the bottom bar are strobed into storage along with the input data, whereas the top bar is directly controlled.

<u>FUNCTION</u>	<u>PIN</u>	<u>FUNCTION</u>	<u>PIN</u>
10 Bit	A	8 Bit 	1
20 Bit	B	4 Bit 	2
40 Bit	C	2 Bit 	3
80 Bit	D	1 Bit 	4
1 k Bit	E	800 Bit	5
2 k Bit	F	400 Bit	6
4 k Bit	H	200 Bit	7
8 k Bit	J	100 Bit	8
10 k Bit 	K	20 k Bit 	9
XX.XXX DP2 	L	XXXX.X DP4 	10
80 K Bit 	M	DC Strobe	11
X.XXXX DP1	N	+5 V dc Power	12
Digital Gnd	P	Strobe Polarity	13
XXX.XX DP3	R	AC Strobe	14
Blanking	S	40 K Bit 	15



OPTION AR, RIGHT ANNUNCIATOR

<u>FUNCTION</u>	<u>PIN</u>
Top Bar	2
Middle Bar	1
Bottom Bar	4
Internal Connection 	3

OPTION ALP, LEFT ANNUNCIATOR

<u>FUNCTION</u>	<u>PIN</u>
+ Polarity	K
10 k Bit	9
Internal Connection 	15
Internal Connection 	M

OPTION ALN, LEFT ANNUNCIATOR

<u>FUNCTION</u>	<u>PIN</u>
Internal Connection 	M
10 k Bit	9
- Polarity	15
Internal Connection 	K

NOTES



-  These pins may change function with options. (See Option Pin Assignments above.)
-  Pins marked "Internal Connection" must be left unconnected.

Figure 4-4 Pin Assignments

DWG. NO.
06306AY-01 D

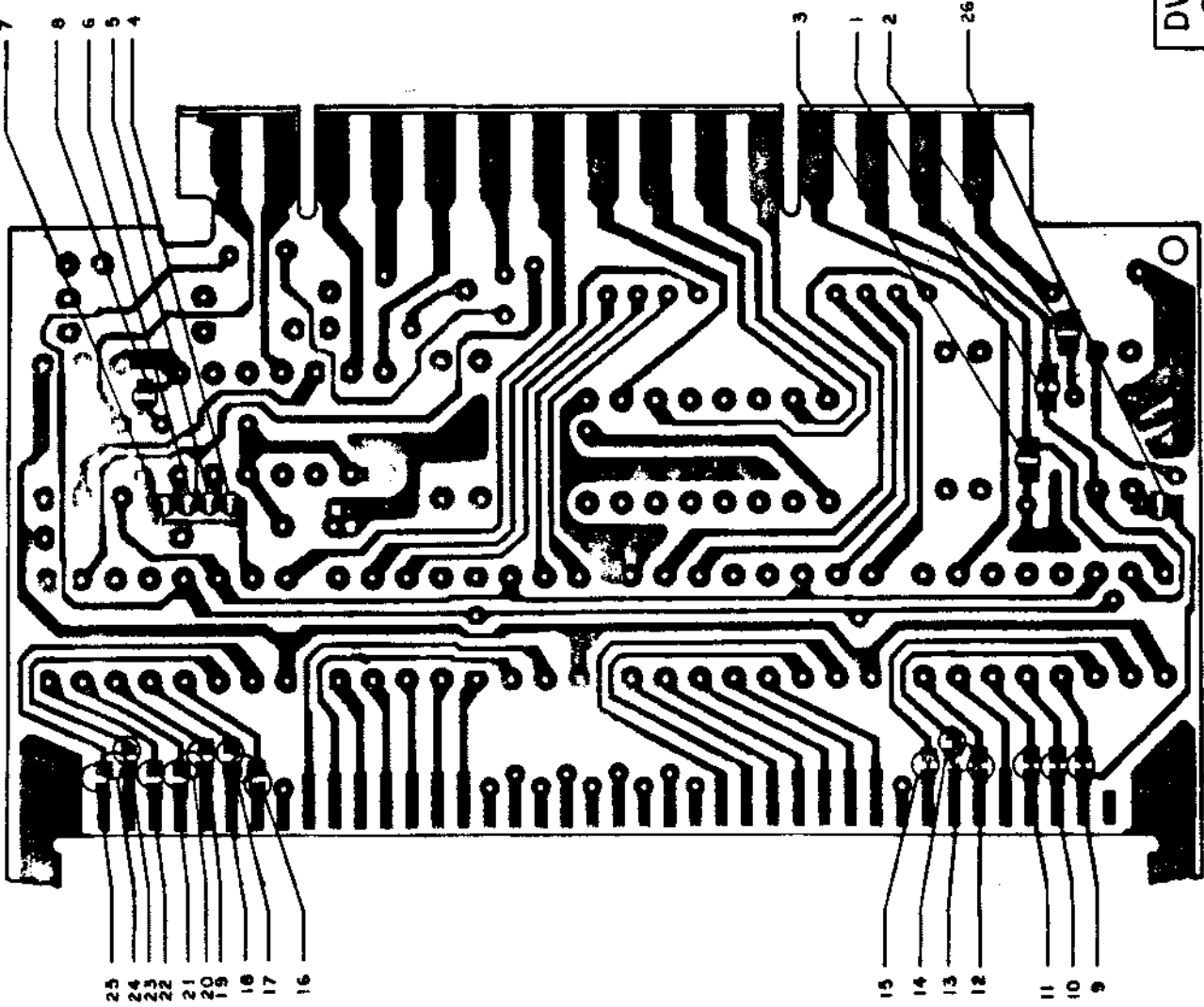
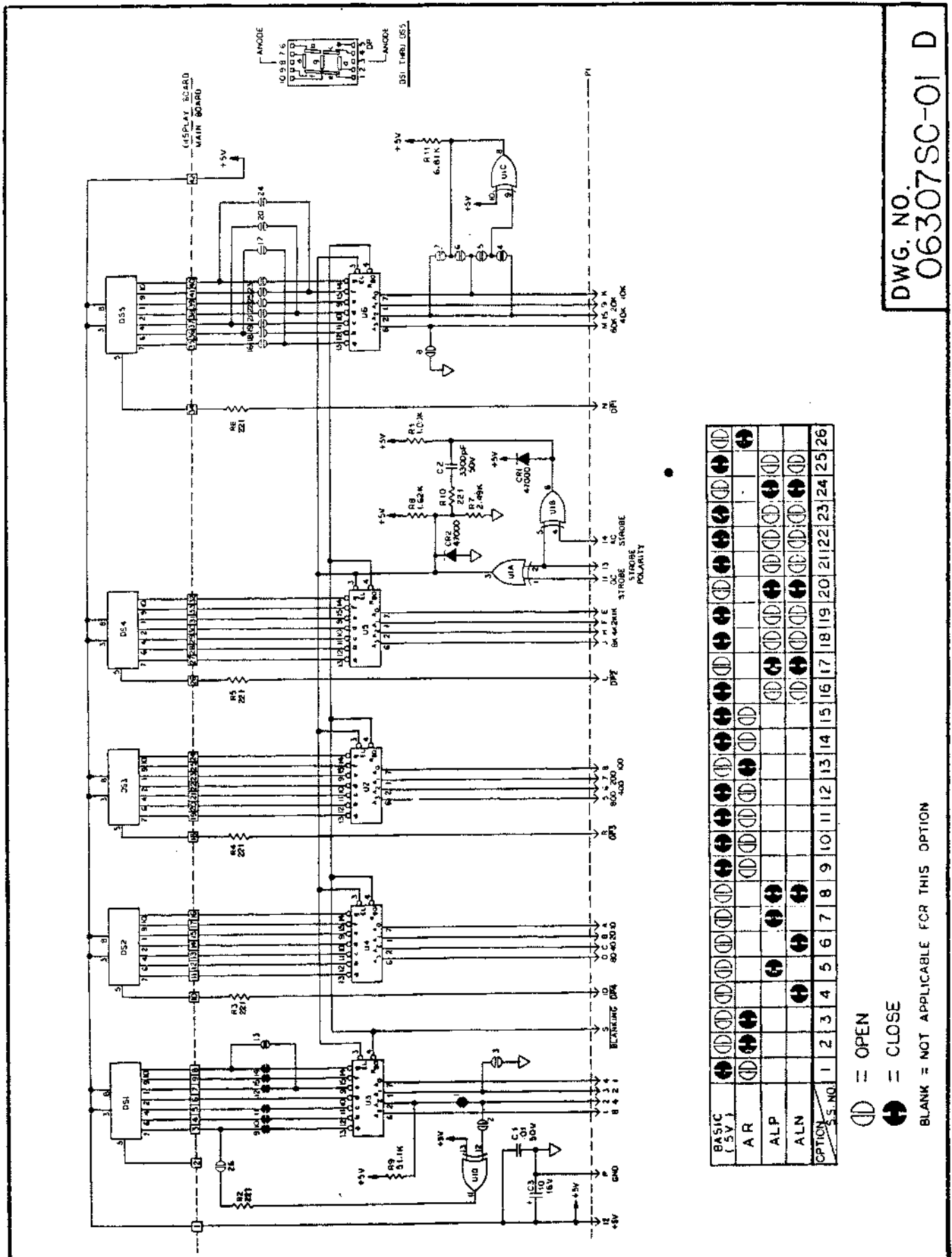

Figure 5-2 Assembly Diagram (2 of 2)



DWG. NO.
06307SC-01 D

Figure 5-3 Schematic Diagram